

DIAGRAMMA PRESTAZIONI

Estensione flusso per $v = 0,3$ m/s in acqua pulita

PERFORMANCE DIAGRAM

Flow extension for $v = 0,3$ m/s in clean water

DIAGRAMME PERFORMANCE

Extension du flux pour $v = 0,3$ m/s en eau propre

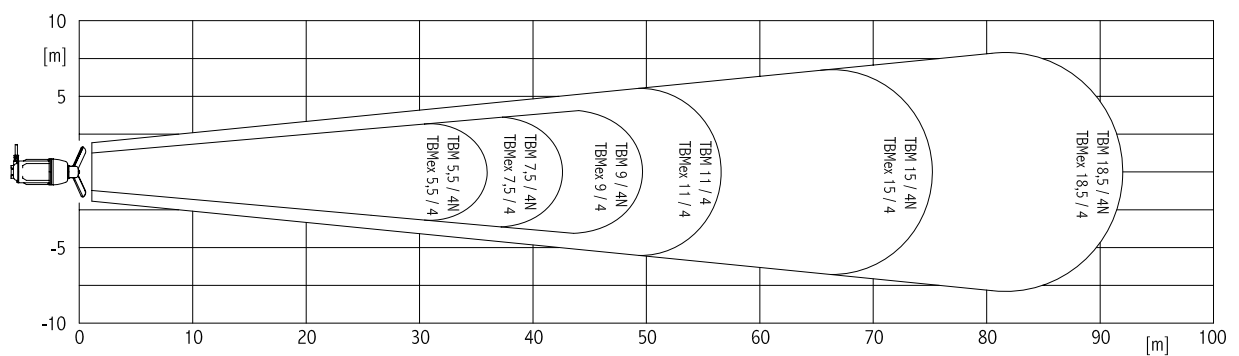
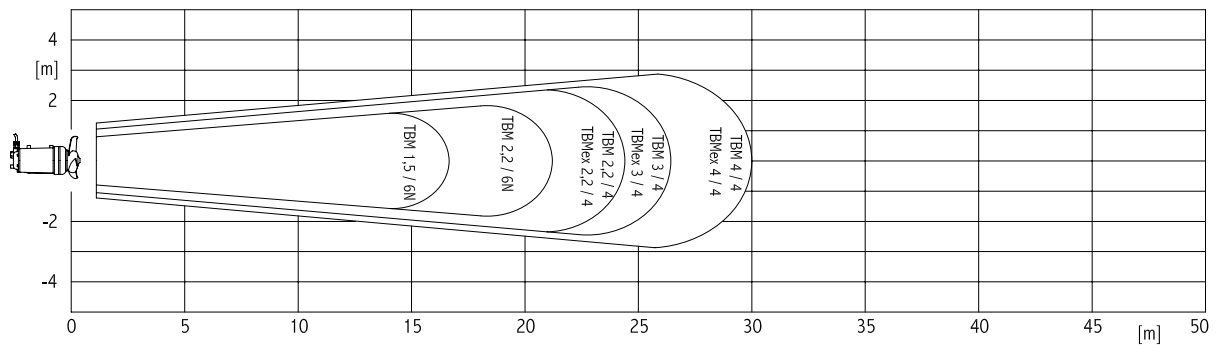

CARATTERISTICHE STANDARD

Motori elettrici asincroni trifase con rotore a gabbia di scoiattolo.
N°2 sonde termiche inserite nell'avvolgimento statorico.
Grado di protezione "IP 68".
Isolamento classe "F".
Max profondità immersione 20 m.
Max contenuto sostanze solide in sospensione 12%.
Cavo sommergibile in neoprene H07-RN-F.
pH liquido 5 ÷ 12.
Max temperatura del liquido pompato 40°C.
Servizio continuo.

STANDARD FEATURES

Asynchronous three phase electric motors with squirrel cage rotor.
N.2 thermic probes installed in the stator winding.
Protection "IP 68".
"F" class insulation.
Max submergence depth: 20 m.
Max solid content in the liquid: 12%.
Submersible H07-RN-F neoprene cable.
Fluid pH 5 - 12.
Max temperature of pumped liquid: 40°C.
Continuous service.

CARACTERISTIQUES STANDARD

Moteurs électriques asynchrones triphasés, rotor à cage d'écureuil.
N°2 sondes thermiques incorporées dans l'enroulement du stator.
Degré de protection "IP 68".
Isolement classe "F".
Max profondeur d'immersion 20 m.
Max contenu de substances solides en suspension 12%.
Max pH du liquide 5 ÷ 12.
Câble submersible en néoprène H07-RN-F.
Max température du liquide pompe 40°C.
Service continu.

CARATTERISTICHE MOTORI TRIFASE - 50Hz - ALIMENTAZIONE 400 V ±10%
50 Hz - THREE-PHASE- MOTOR FEATURES - VOLTAGE RATING 400 V ±10%
CARACTERISTIQUES DES MOTEURS TRIPHASES - 50Hz - ALIMENTATION 400 V ±10%

CARATTERISTIC. MISCELATORE
MIXER CHARACTERISTICS
CARACTERISTIQ. MELANGEUR

Standard	Tipo Type Type	Atex	Potenza Mot. Motor Rating Puissance Mot.	Avvolgimen. Windings Bobinage	Assorbimento Absorption Intensité	Cavo - Cable - Cable			Avviamento		N° pale Blades N. Pales N.	Giri/min RPM T/min	Portata Capacity Débit	Spinta ass.* Axial force* Poussée axl.*
						N°cavi N°cables N°cables	N° conduttori cavo x sez. N° of wires x size N° conducteurs câble à sect.	Lunghezza cavo Cable length [m] Longueur câble	Diretto Direct Direct	Indiretto Indirect Indirect				
TBM 1,5 / 6N			1,5	230-400	4,2	1	9 x 1,5	10	↘	↘	3	925	643	230
TBM 2,2 / 6N			2,2		5,9							940	876	313
TBM 2,2 / 4	TBMex 2,2 / 4	2,2	5,3		323							1333	441	
TBM 3 / 4	TBMex 3 / 4	3	6,8		323							1581	580	
TBM 4 / 4	TBMex 4 / 4	4	400-690	9,1	1	9 x 2,5	10	△	↘-△	2	320	2146	853	
TBM 5,5 / 4N	TBMex 5,5 / 4	5,5		12,5							326	2391	981	
TBM 7,5 / 4N	TBMex 7,5 / 4	7,5		15,8							328	3254	1520	
TBM 9 / 4N	TBMex 9 / 4	9		19							328	3628	1826	
TBM 11 / 4	TBMex 11 / 4	11	23,5	9 x 4	1	9 x 4	10	△	↘-△	2	351	3977	2158	
TBM 15 / 4N	TBMex 15 / 4	15	30								351	5335	2697	
TBM 18,5 / 4N	TBMex 18,5 / 4	18,5	36								354	6884	3826	

* Valori ricavati in accordo alla ISO 21630
* Values according to ISO 21630
* Les valeurs obtenues sont conformes à l'ISO 21630

TBM 1,5 / 6N
TBM 2,2 / 6N

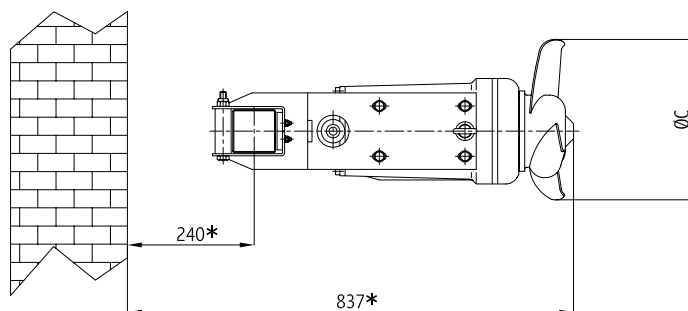
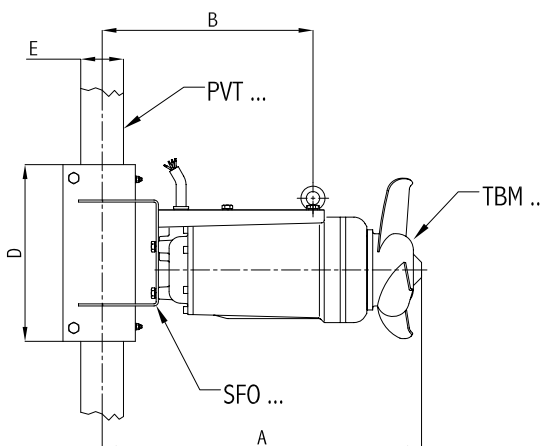
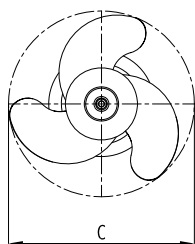

Tipo Type Type	Motore Motor Moteur	DIMENSIONI INGOMBRO OVERALL DIMENSIONS DIMENSIONS D'ENCOMBREMENT					Peso Weight Poids
		[mm]					
	[kW]	A	B	C	D	∅E	[kg]
TBM 1,5 / 6N	1,5	595	395	297	330	80x80	60,5
TBM 2,2 / 6N	2,2			347			58,5

* TBM + PVT/GVT + SFO

TBM 2,2 / 4	TBM 5,5 / 4N	TBM 11 / 4
TBMex 2,2 / 4	TBMex 5,5 / 4	TBMex 11 / 4
TBM 3 / 4	TBM 7,5 / 4N	TBM 15 / 4N
TBMex 3 / 4	TBMex 7,5 / 4	TBMex 15 / 4
TBM 4 / 4	TBM 9 / 4N	TBM 18,5 / 4N
TBMex 4 / 4	TBMex 9 / 4	TBMex 18,5 / 4

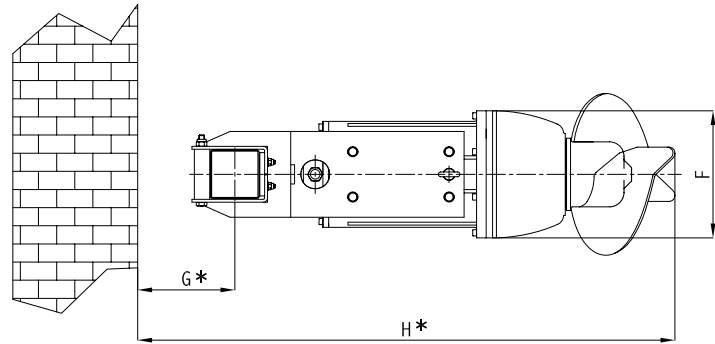
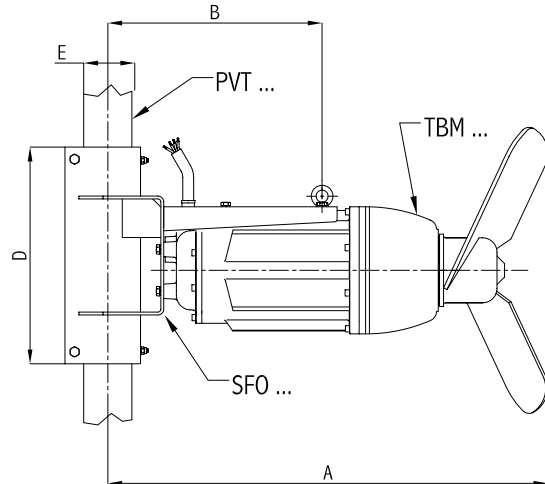
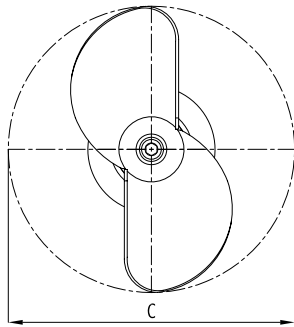

Tipo Type Type	Motore Motor Moteur	DIMENSIONI INGOMBRO OVERALL DIMENSIONS DIMENSIONS D'ENCOMBREMENT [mm]								Peso Weight Poids [kg]
		[kW]	A	B	C	D	∅E	F	G*	
TBM 2,2 / 4	2,2	820	395	445	330	80x80	197	240	1060	77
TBMex 2,2 / 4				79						
TBM 3 / 4	3	830	395	460	330	80x80	197	240	1070	79
TBMex 3 / 4				81						
TBM 4 / 4	4	840	395	515	330	80x80	197	240	1080	81
TBMex 4 / 4				83						
TBM 5,5 / 4N	5,5	889	445	535	450	100x100	264	250	1139	115
TBMex 5,5 / 4				118						
TBM 7,5 / 4N	7,5	903	445	585	450	100x100	264	250	1153	121,5
TBMex 7,5 / 4				124,5						
TBM 9 / 4N	9	914	445	595	450	100x100	264	250	1164	127
TBMex 9 / 4				130						
TBM 11 / 4	11	1035	505	600	550	100x100	310	250	1285	185
TBMex 11 / 4				189						
TBM 15 / 4N	15	1030	505	720	550	100x100	310	250	1280	199
TBMex 15 / 4				203						
TBM 18,5 / 4N	18,5	1045	505	780	550	100x100	310	250	1295	204
TBMex 18,5 / 4				208						

* TBM + PVT/GVT + SFO

INSTALLAZIONI POSSIBILI - POSSIBLE INSTALLATIONS - INSTALLATIONS POSSIBLES

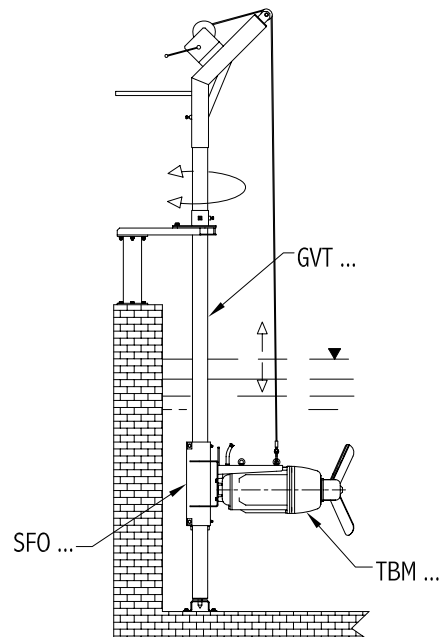
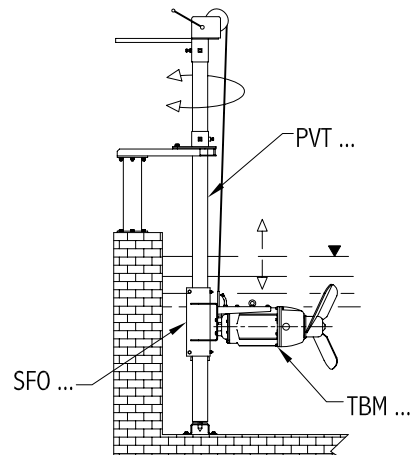
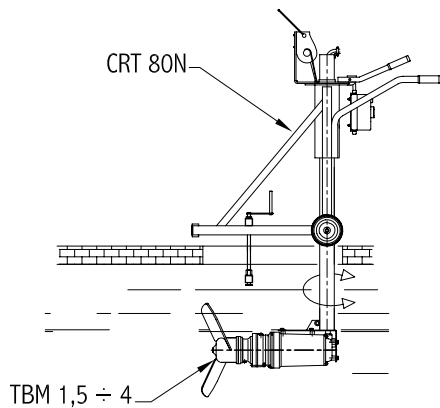
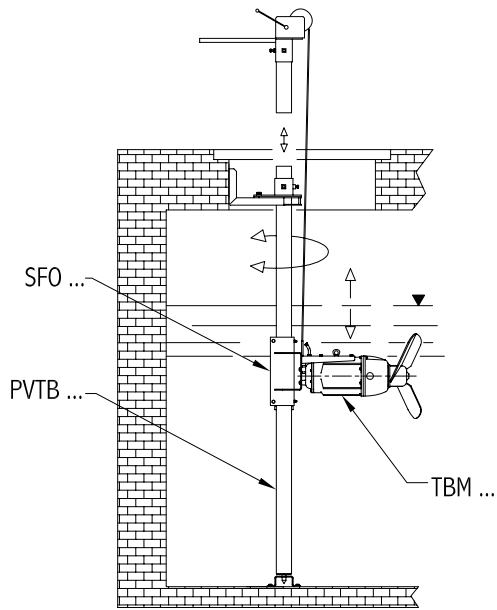
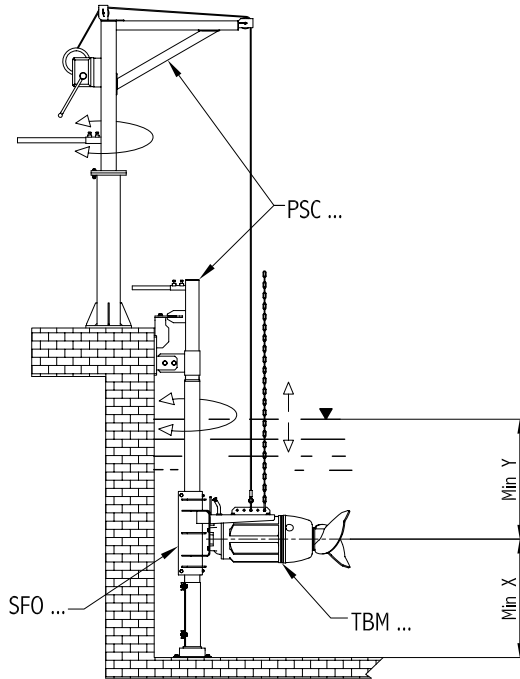

SOMMERGENZA MINIMA RACCOMANDATA RECOMMENDED MINIMUM SUBMERGENZE RECOMMANDÉE SUBMERSION MINIMUM		[mm]	
Tipo - Type - Type		Min X	Min Y
TBM 1,5 / 6N		500	600
TBM 2,2 / 6N			
TBM 2,2 / 4	TBMex 2,2 / 4	500	700
TBM 3 / 4	TBMex 3 / 4		
TBM 4 / 4	TBMex 4 / 4		
TBM 5,5 / 4N	TBMex 5,5 / 4	670	750
TBM 7,5 / 4N	TBMex 7,5 / 4		
TBM 9 / 4N	TBMex 9 / 4		
TBM 11 / 4	TBMex 11 / 4	710	850
TBM 15 / 4N	TBMex 15 / 4		
TBM 18,5 / 4N	TBMex 18,5 / 4		

ACCESSORI - ACCESSORIES - ACCESSOIRES

Tipo Type Type	Paranco con verricello e tubo guida Hoist winch and rail pipe Treuil poulie et barre de guidage	Piantone Spacer Colonne	Paranco con verricello e tubo guida Hoist winch and rail pipe Treuil poulie et barre de guidage	
TBM 1,5 / 6N	PVT 80 / ... PXT 80 / ...	PT 80	PVTB 80 / ...	
TBM 2,2 / 6N				
TBM 2,2 / 4				
TBMex 2,2 / 4				
TBM 3 / 4				
TBMex 3 / 4				
TBM 4 / 4				
TBMex 4 / 4	PVT 100 / ... PXT 100 / ...	PT 100	PVTB 100 / ...	
TBM 5,5 / 4N				
TBMex 5,5 / 4				
TBM 7,5 / 4N				
TBMex 7,5 / 4				
TBM 9 / 4N				
TBMex 9 / 4				
TBM 11 / 4 PVT 150 / ...N PXT 150 / ...N	PVTB 150 / ...N	
TBMex 11 / 4				
TBM 15 / 4N				
TBMex 15 / 4				
TBM 18,5 / 4N				
TBMex 18,5 / 4				
TBMex 18,5 / 4				
Tipo Type Type	Paranco con verricello e tubo guida Hoist winch and rail pipe Treuil poulie et barre de guidage	Kit di sollevamento Lifting kit Kit de levage		Fermacavo Cable stop Arrêt de câble
TBM 1,5 / 6N	GVT 80 / ...	KIT PVT 80	FC 16
TBM 2,2 / 6N				
TBM 2,2 / 4				
TBMex 2,2 / 4				
TBM 3 / 4				
TBMex 3 / 4				
TBM 4 / 4				
TBMex 4 / 4	GVT 100 / ...	KIT PVT 100	FC 20
TBM 5,5 / 4N				
TBMex 5,5 / 4				
TBM 7,5 / 4N				
TBMex 7,5 / 4				
TBM 9 / 4N				
TBMex 9 / 4				
TBM 11 / 4	KIT PVT 150N	FC 26
TBMex 11 / 4				
TBM 15 / 4N				
TBMex 15 / 4				
TBM 18,5 / 4N				
TBMex 18,5 / 4				
TBMex 18,5 / 4				

ACCESSORI - ACCESSORIES - ACCESSOIRES

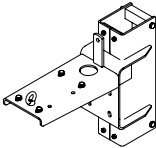
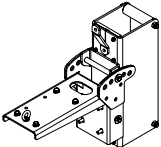
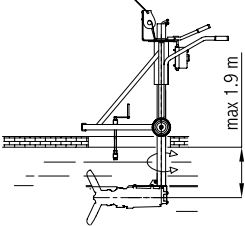
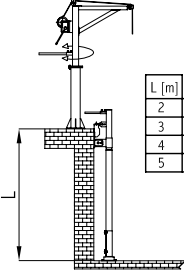
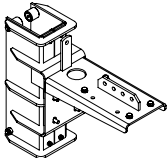
	Staffa motore Motor bracket Console du moteur	Staffa motore inclinabile Adjustable motor bracket Console réglable du moteur	Carrello per pozzetti Trolley Régable	Paranco con verricello e tubo guida Hoist winch and rail pipe Trebail poulie et barre de guidage	Staffa motore con rullini Motor bracket with rolls Console du moteur avec galets										
Tipo Type Type				 <table border="1" data-bbox="1182 383 1278 483"> <tr><td>L [m]</td><td></td></tr> <tr><td>2</td><td>PSC../2</td></tr> <tr><td>3</td><td>PSC../5</td></tr> <tr><td>4</td><td>PSC../5</td></tr> <tr><td>5</td><td>PSC../5</td></tr> </table>	L [m]		2	PSC../2	3	PSC../5	4	PSC../5	5	PSC../5	
L [m]															
2	PSC../2														
3	PSC../5														
4	PSC../5														
5	PSC../5														
TBM 1,5 / 6N	SFO 80	SRO 80	CRT 80N	PSC 80 / ...	SFO 80W										
TBM 2,2 / 6N															
TBM 2,2 / 4															
TBMex 2,2 / 4															
TBM 3 / 4															
TBMex 3 / 4															
TBM 4 / 4															
TBMex 4 / 4															
TBM 5,5 / 4N	SFO 100	SRO 100	PSC 100 / ...	SFO 100W										
TBMex 5,5 / 4															
TBM 7,5 / 4N															
TBMex 7,5 / 4															
TBM 9 / 4N															
TBM 11 / 4	SFO 150	SRO 150	PSC 100 / ...	SFO 150W										
TBMex 11 / 4															
TBM 15 / 4N															
TBMex 15 / 4															
TBM 18,5 / 4N															
TBMex 18,5 / 4															

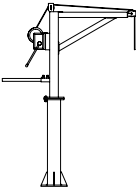
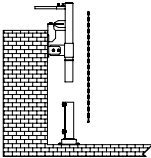
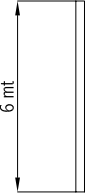
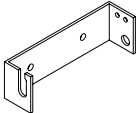
	Kit gru con verricello Cranes and winch kit Kit grues et poulie	Kit fissaggio tubo guida Fixing kit for rail pipe Kit de fixation pour tuyau de guide	Tubo guida Rail pipe Tube de guidage	Staffa attacco catena e fune Bracket for chain and rope Support pour chaîne et corde
Tipo Type Type				
TBM 1,5 / 6N	KIT PVG 80	KIT PTG 80	KIT PGI 80	SCF
TBM 2,2 / 6N				
TBM 2,2 / 4				
TBMex 2,2 / 4				
TBM 3 / 4				
TBMex 3 / 4				
TBM 4 / 4				
TBMex 4 / 4				
TBM 5,5 / 4N	KIT PVG 100	KIT PTG 100	KIT PGI 100	SCF
TBMex 5,5 / 4				
TBM 7,5 / 4N				
TBMex 7,5 / 4				
TBM 9 / 4N				
TBMex 9 / 4				
TBM 11 / 4	KIT PVG 100	KIT PTG 100	KIT PGI 100	SCF
TBMex 11 / 4				
TBM 15 / 4N				
TBMex 15 / 4				
TBM 18,5 / 4N	KIT PVG 100	KIT PTG 100	KIT PGI 100	SCF
TBMex 18,5 / 4				